

Betriebs- & Montageanleitung Libretto istruzioni Notice d'emploi et d'entretien

QE-B I/M QE-B I/M VK90

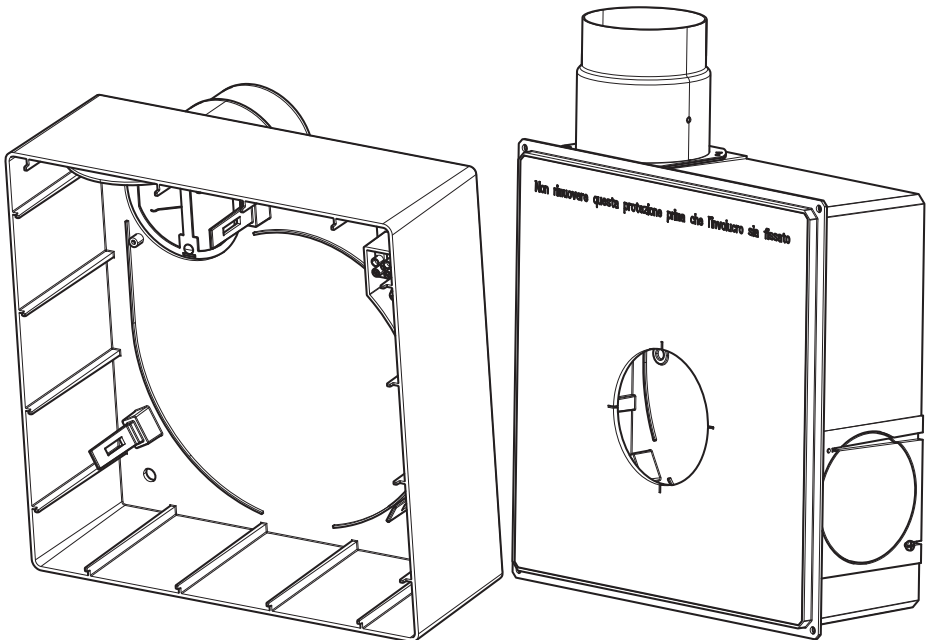

Informazione importante per lo smaltimento ambientalmente compatibile

IN ALCUNI PAESI DELL'UNIONE EUROPEA QUESTO PRODOTTO NON RICADE NEL CAMPO DI APPLICAZIONE DELLA LEGGE NAZIONALE DI RECEPIMENTO DELLA DIRETTIVA RAEE E QUINDI NON È IN ESSI VIGENTE ALCUN OBBLIGO DI RACCOLTA DIFFERENZIATA A FINE VITA.

Questo prodotto è conforme alla Direttiva EU 2012/19/EC.

Il simbolo del bidone barrato riportato sull'apparecchio indica che il prodotto, alla fine della propria vita utile, dovendo essere trattato separatamente dai rifiuti domestici, deve essere conferito in un centro di raccolta differenziata per apparecchiature elettriche ed elettroniche oppure riconsegnato al rivenditore al momento dell'acquisto di una nuova apparecchiatura equivalente.



L'utente è responsabile del conferimento dell'apparecchio a fine vita alle appropriate strutture di raccolta, pena le sanzioni previste dalla vigente legislazione sui rifiuti.

L'adeguata raccolta differenziata per l'avvio successivo dell'apparecchio smesso al riciclaggio, al trattamento e allo smaltimento ambientalmente compatibile contribuisce ad evitare possibili effetti negativi sull'ambiente e sulla salute e favorisce il riciclo dei materiali di cui è composto il prodotto.

Per informazioni più dettagliate inerenti i sistemi di raccolta disponibili, rivolgersi al servizio locale di smaltimento rifiuti o al negozio in cui è stato effettuato l'acquisto.

I produttori e gli importatori ottemperano alla loro responsabilità per il riciclaggio, il trattamento e lo smaltimento ambientalmente compatibile sia direttamente sia partecipando ad un sistema collettivo.

Important information on environmentally compatible disposal

In certain European Union countries this appliance is not subject to the requirements of national laws implementing the WEEE Directive; consequently, there is no obligation to observe sorted collection procedures when disposing of the appliance in these countries.

This appliance complies with European Directive EU 2012/19/EC.

Where an appliance is marked with the crossed-out wheeled bin symbol, this means that, at the end of its useful life, the product has to be disposed of separately from household waste: it must be taken to a sorted collection centre for electrical and electronic appliances or returned to the retailer when a new equivalent appliance is purchased.



The user is responsible for taking the appliance to a designated collection centre at the end of its useful life, and liable to penalties applicable under current statutory regulations on waste disposal.

Appropriate sorted waste collection for subsequent recycling, treatment and eco-compatible disposal of decommissioned appliances helps to prevent any possible negative impact on the environment and on health, and favours recycling of the materials used in the manufacture of the product.

For more detailed information on available waste collection systems, contact the local waste disposal service or the shop where the product was purchased.

Manufacturers and importers comply with their responsibility for recycling, treating and eco-compatible disposal of waste both directly and collectively.

Information importante pour une élimination compatible avec l'environnement

POUR CERTAINS PAYS DE L'UNION EUROPÉENNE, CET APPAREIL N'ENTRE PAS DANS LE CHAMP DE TRANSDITION DE LA DIRECTIVE DEEE DANS LES LÉGISLATIONS NATIONALES : IL N'EXISTE DANS CE CAS AUCUNE OBLIGATION DE COLLECTE DIFFÉRENCIÉE À LA FIN DE SON CYCLE DE VIE.

Cet appareil est conforme à la Directive EU 2012/19/EC.

Le symbole de la poubelle barrée apposé sur l'appareil indique qu'il doit être traité séparément des déchets domestiques à la fin de son cycle de vie et remis à un centre de collecte différenciée pour équipements électriques et électroniques ou au revendeur lors de l'achat d'un nouvel appareil.

L'utilisateur est responsable de la remise de l'appareil aux structures de collecte appropriées à la fin de son cycle de vie sous peine des sanctions prévues par la législation en vigueur en matière d'élimination des déchets.

La collecte différenciée qui permet de recycler l'appareil, de le retraiter et de l'éliminer en respectant l'environnement contribue à éviter la pollution du milieu et ses effets sur la santé et favorise la réutilisation des matériaux qui le composent.

Pour plus d'informations sur les systèmes de collecte existants, s'adresser au service local d'élimination des déchets ou au magasin dans lequel l'appareil a été acheté.

Les fabricants et les importateurs satisfont à leurs obligations environnementales en matière de recyclage, de traitement et d'élimination des déchets, directement ou en participant à un système collectif.



DEUTSCH

Wichtige Information für die umweltgerechte Entsorgung

IN EINIGEN EU-LÄNDERN GELTEN FÜR DIESES PRODUKT NICHT DIE VORGABEN DER EUROPÄISCHEN RICHTLINIE ÜBER ELEKTRO- UND ELEKTRONIK-ALTGERÄTE (WEEE-RICHTLINIE) UND DEMNACH BESTEHT IN DIESEN LÄNDERN AUCH KEINE PFLICHT FÜR DIE MÜLLTRENNUNG BEI DER ENTSORGUNG DES GERÄTS.

Dieses Gerät erfüllt die Bestimmungen der europäischen Richtlinie EU 2012/19/EC über Elektro- und Elektronik-Altgeräte.

Die auf dem Gerät abgebildete durchgekennzeichnete Mülltonne bedeutet, dass das Gerät nach seiner Nutzungsdauer nicht als Hausmüll, sondern über eine Wertstoffsammelstelle für elektrische und elektronische Altgeräte entsorgt werden bzw. dem Händler beim Kauf eines Ersatzgeräts zur vorschriftsmäßigen Entsorgung übergeben werden muss.

Der Betreiber ist für die vorschriftsmäßige Entsorgung des Altgerätes verantwortlich, im Fall einer Nichteinhaltung sieht die geltende Gesetzgebung zur Abfallbeseitigung entsprechende Strafen vor.

L'adeguata raccolta differenziata per l'avvio successivo dell'apparecchio dismesso al riciclaggio, al trattamento e allo smaltimento ambientalmente compatibile contribuisce ad evitare possibili effetti negativi sull'ambiente e sulla salute e favorisce il riciclo dei materiali di cui è composto il prodotto.

Nähere Auskünfte zu den verfügbaren Sammelsystemen erhalten Sie bei Ihrer örtlichen Wertstoffsammelstelle oder vom Händler, bei dem Sie das Gerät gekauft haben.

Die Hersteller und die Importeure kommen ihrer Pflicht hinsichtlich der umweltgerechten Entsorgung und Wiederverwertung direkt oder indirekt durch die Teilnahme an Kollektivsystemen nach.



QE - B I

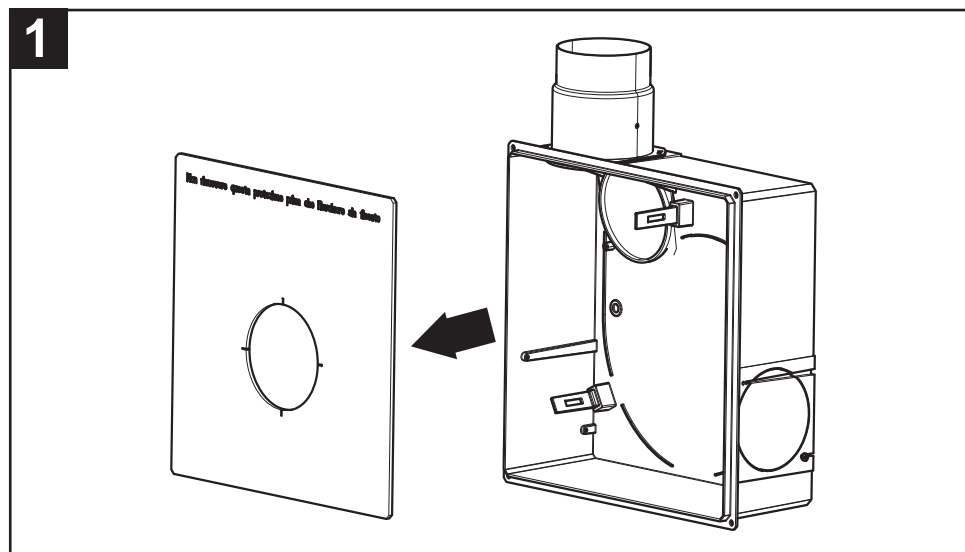
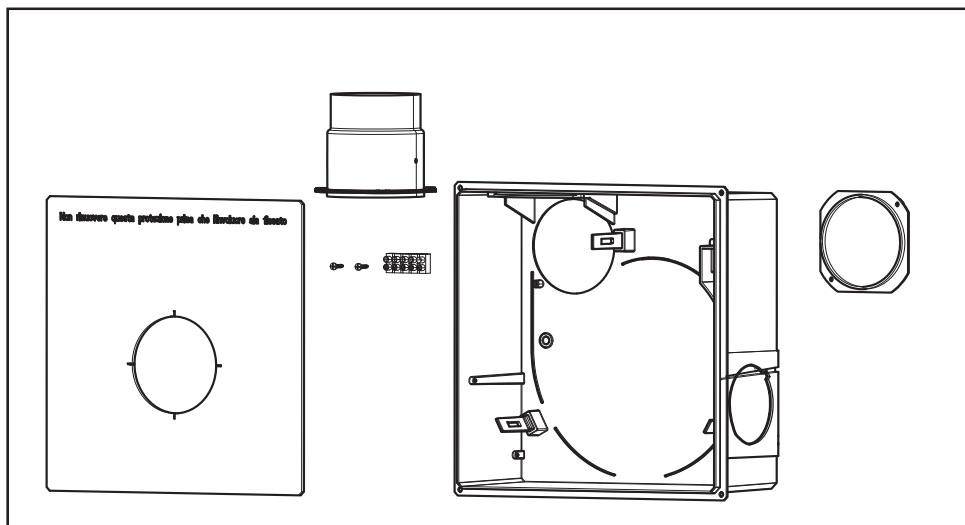

2

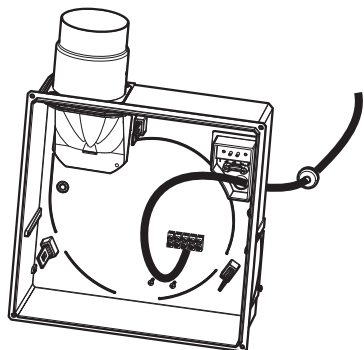

3

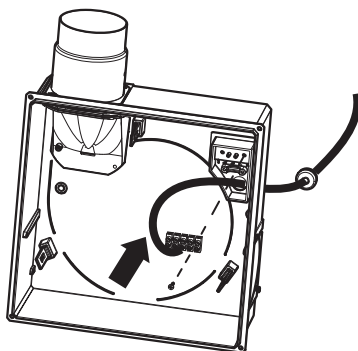

QE - B I (WALL, WAND)

4

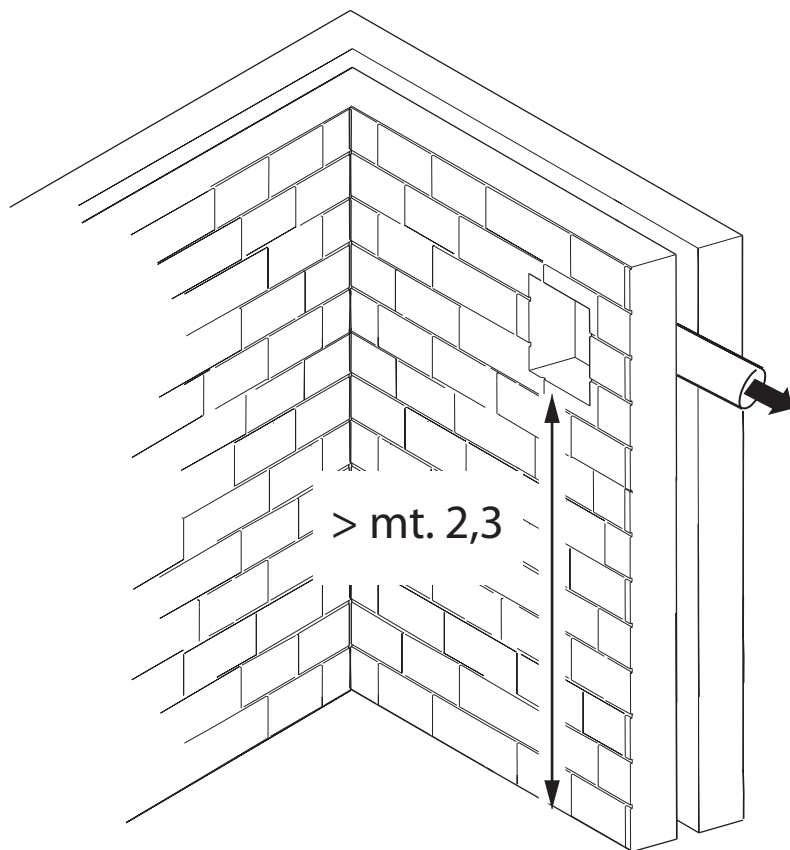

4-1

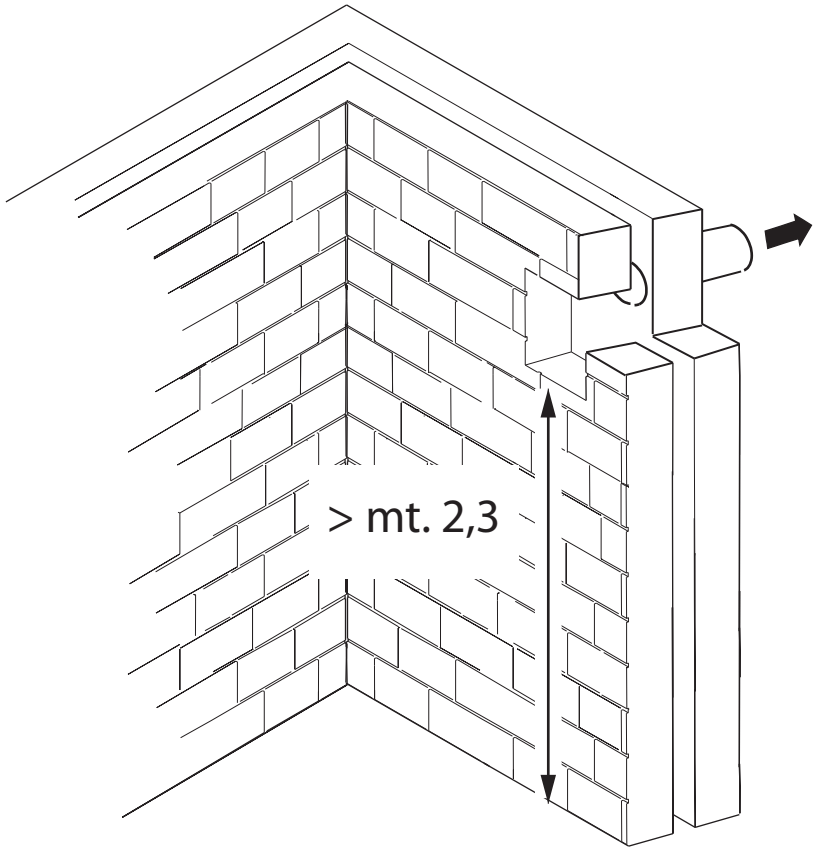

5

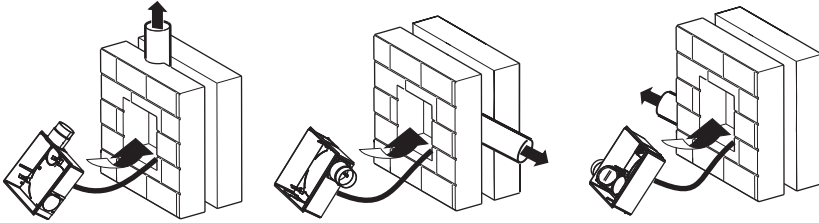
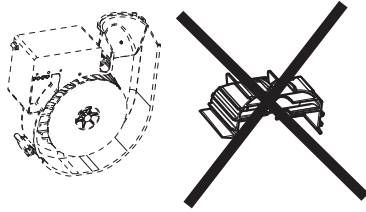

5-1

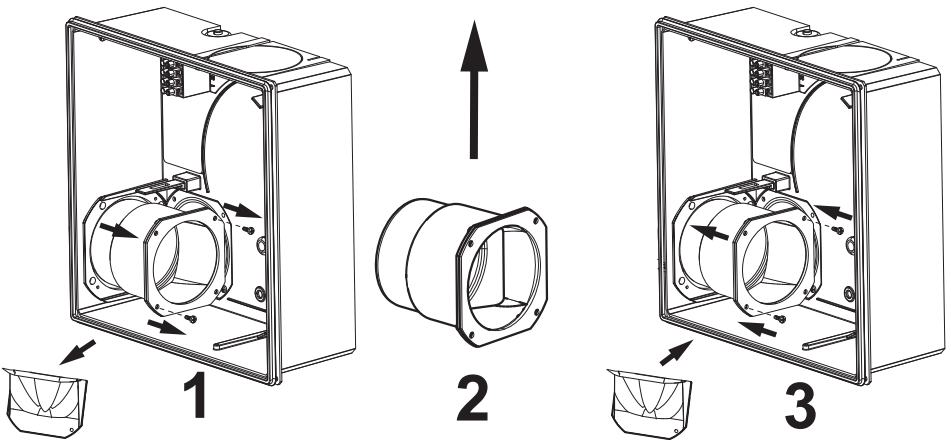
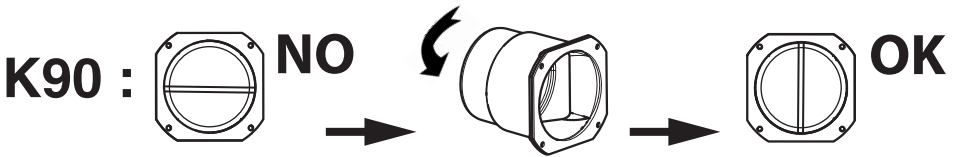
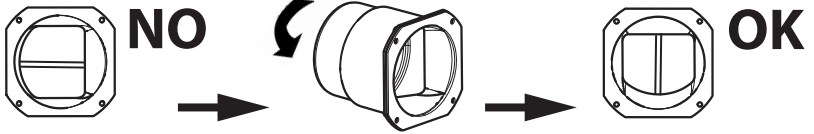

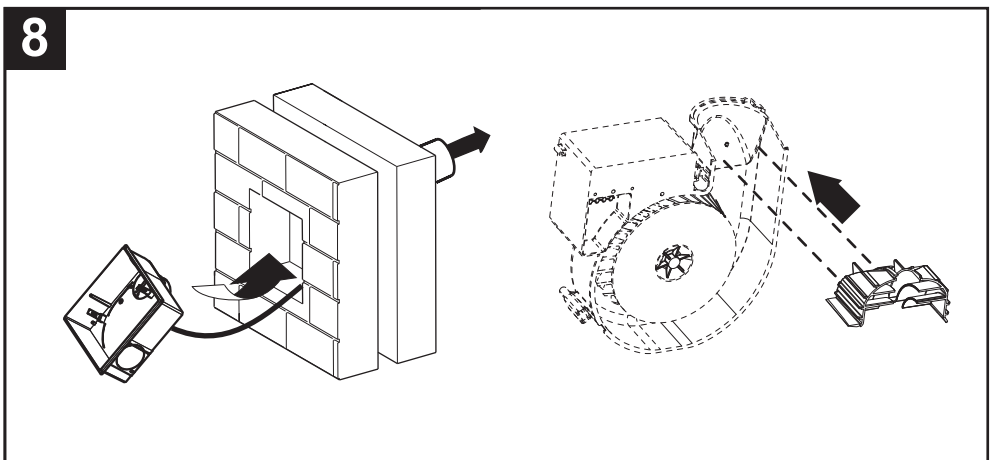
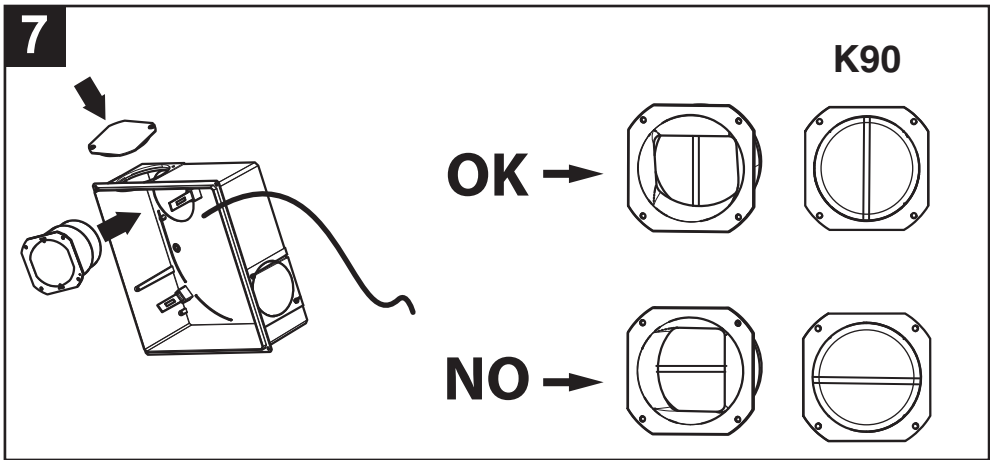
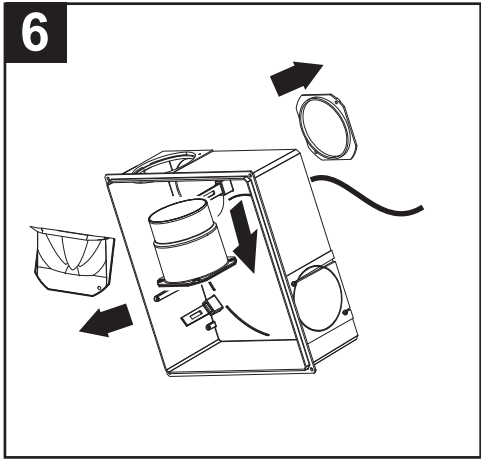

9

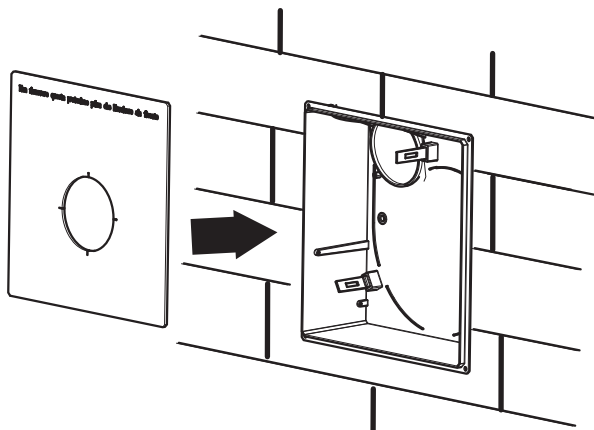

10

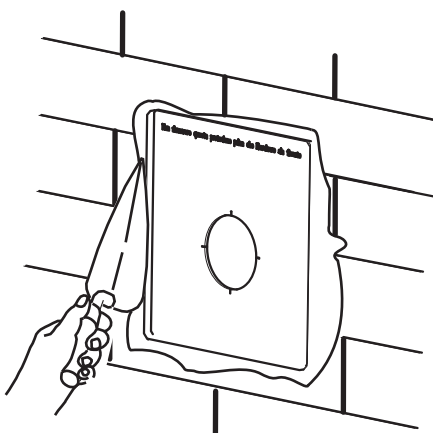

QE - B I (CEILING, DECKE)

11

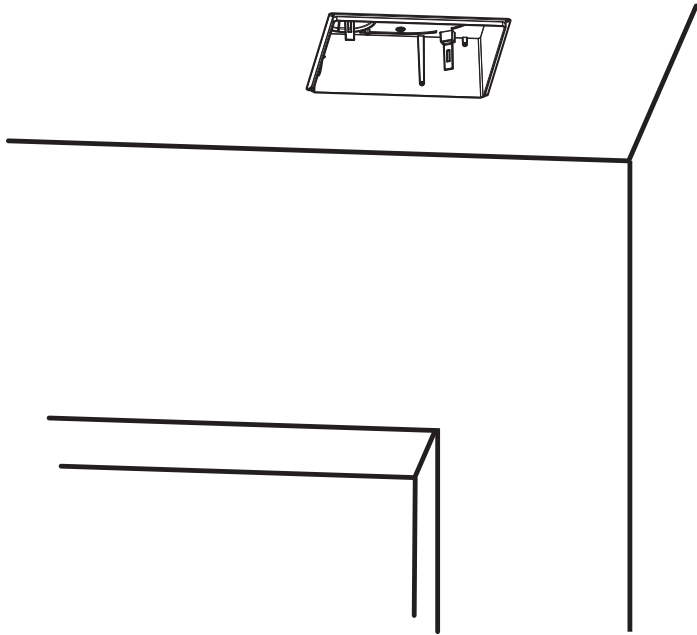

12

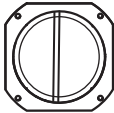
K90 :  OK

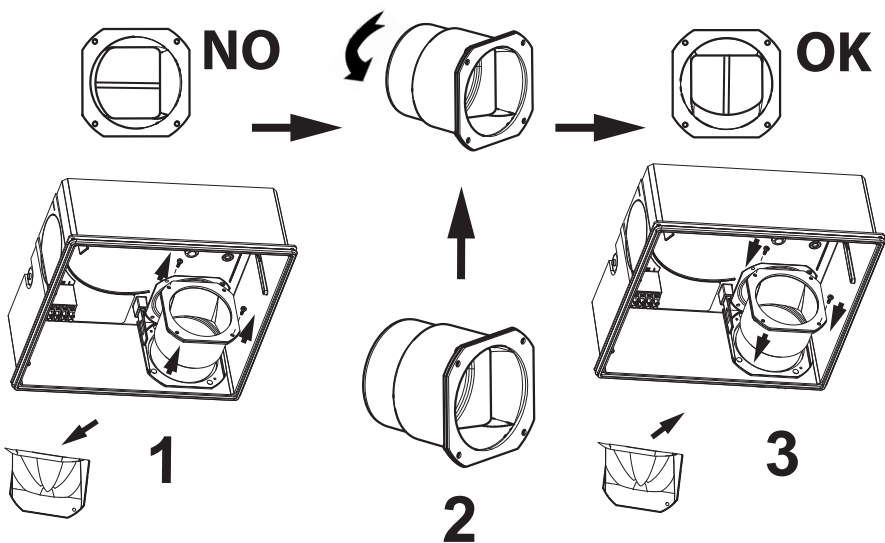

QE - B M

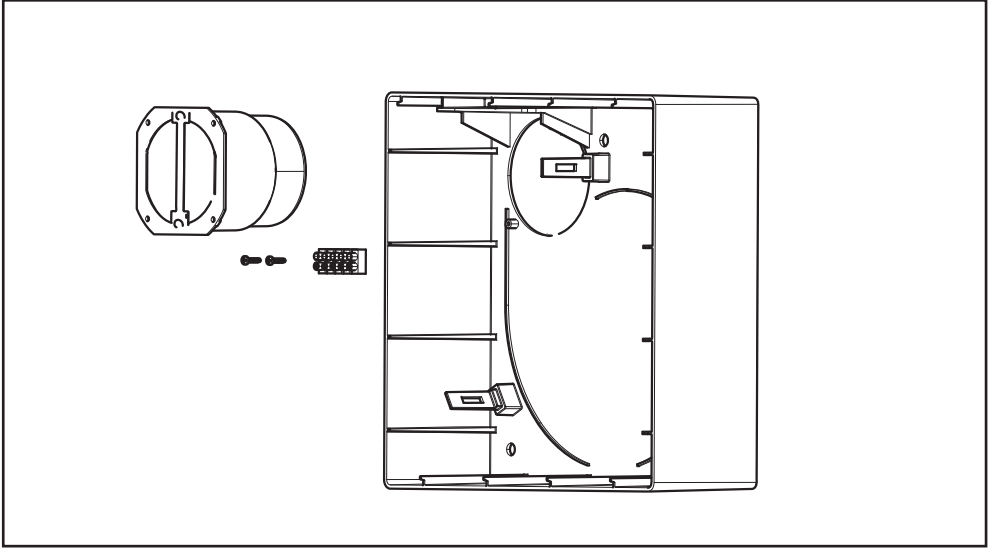

13

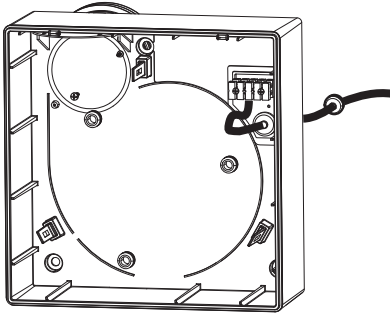

14

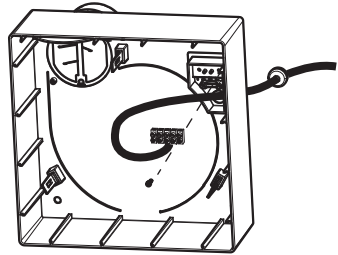

15

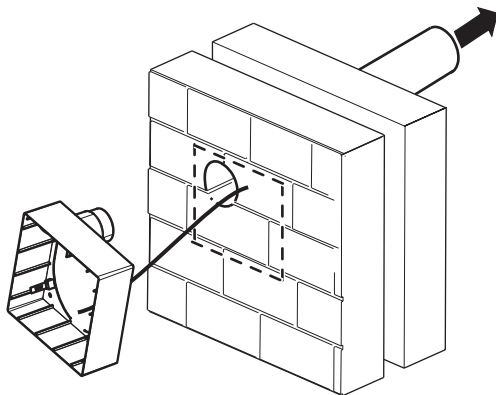

16

K90

NO →

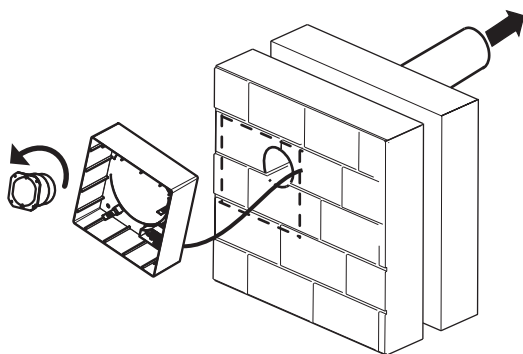
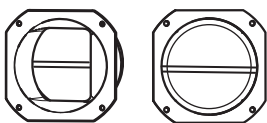

OK →

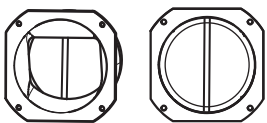

17

K90

NO →

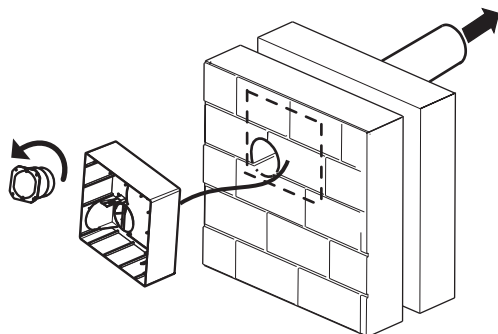
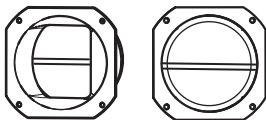

OK →

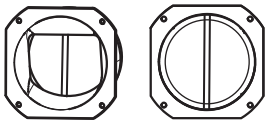

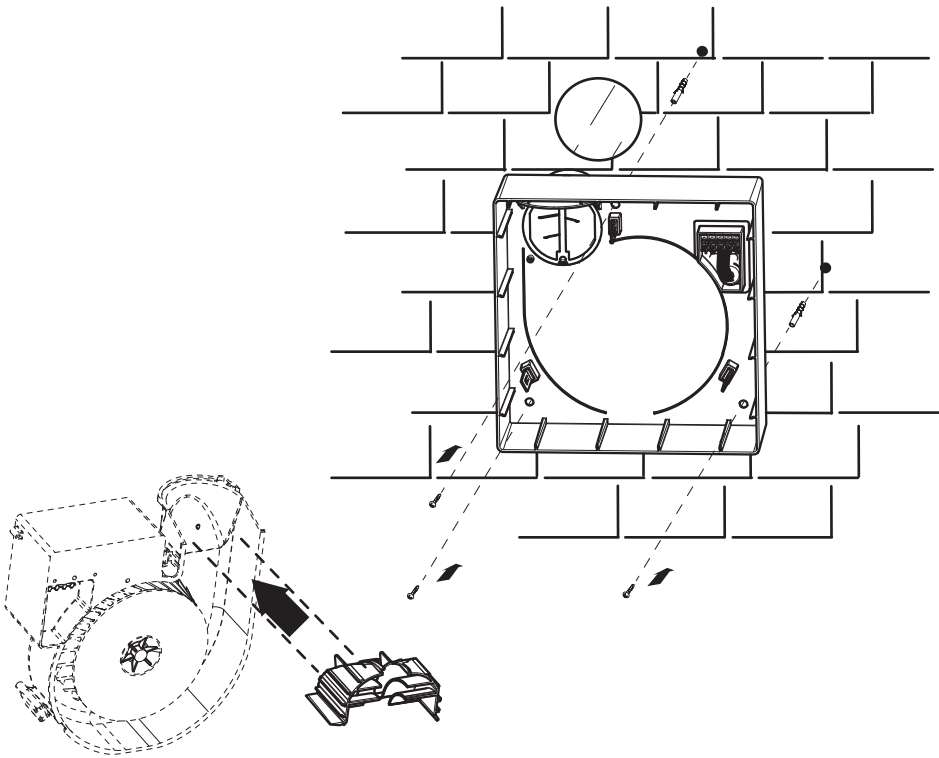

19

QE 60 LL

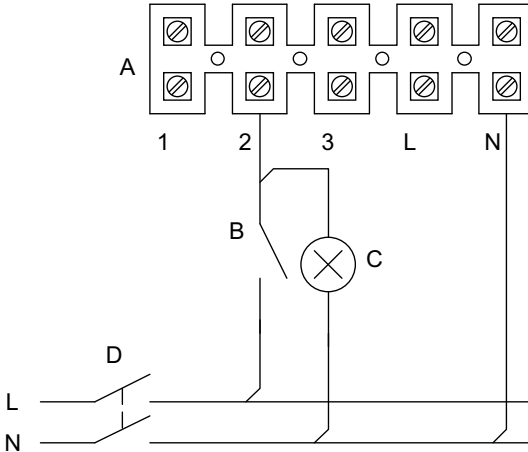

- A Hauptklemmleiste
- B 60m3/h Schalter
- C Raumlicht
- D Bipolarer Hauptschalter

20

QE 60 LL T

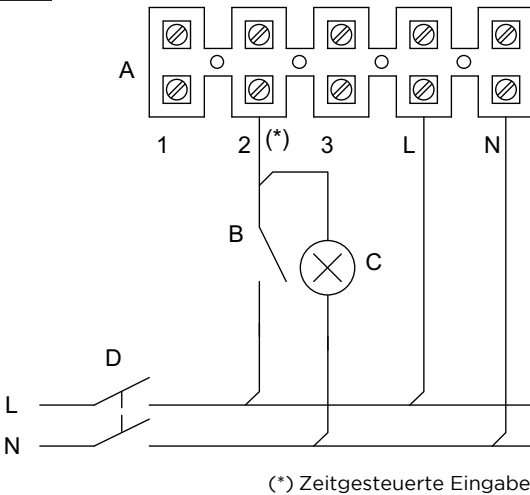

- A Hauptklemmleiste
- B 60m3/h Schalter
- C Raumlicht
- D Bipolarer Hauptschalter

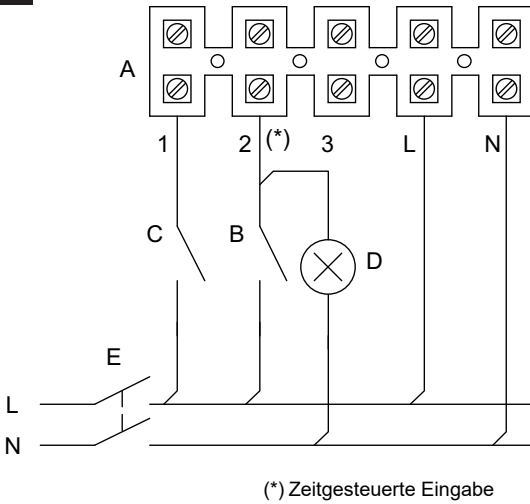
21

QE 60 LL TP
QE 60 LL TP HCS

- A Hauptklemmleiste
- B 60m³/h Schalter
- C Ausschalter
- D Raumlicht
- E Bipolarer Hauptschalter

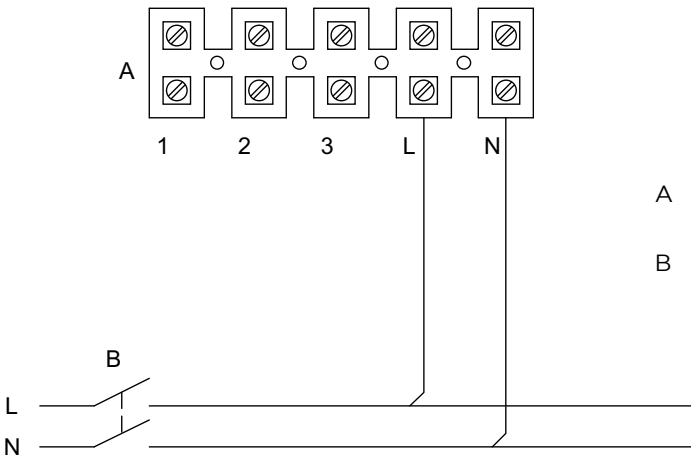
22

QE 60 LL T PIR
QE 100 LL T PIR

- A Hauptklemmleiste
- B Bipolarer Schalter

23

QE 100 LL

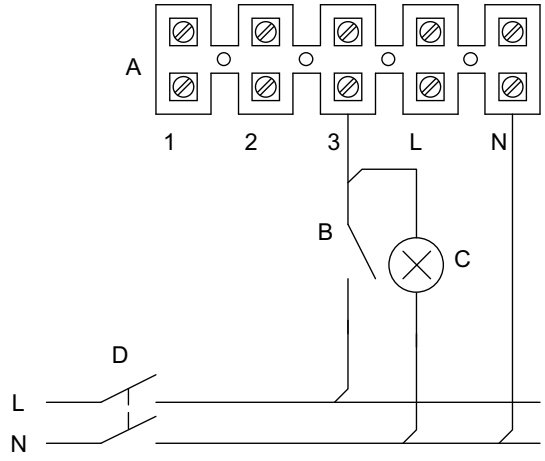

- A Hauptklemmleiste
- B 100m³/h Schalter
- C Raumlicht
- D Bipolarer Hauptschalter

24

QE 100 LL T

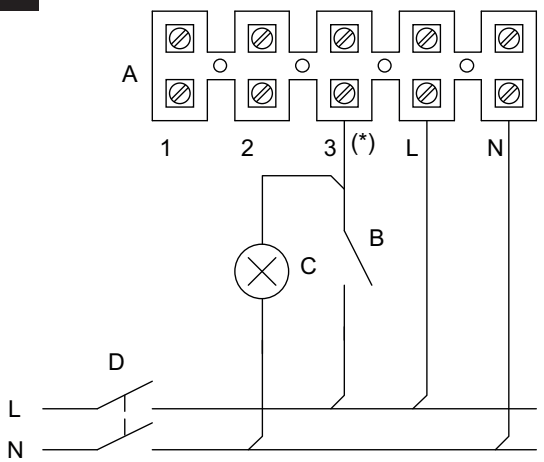

- A Hauptklemmleiste
- B 100m³/h Schalter
- C Raumlicht
- D Bipolarer Hauptschalter

(*) Zeitgesteuerte Eingabe

QE 100 LL TP
QE 100 LL TP HCS

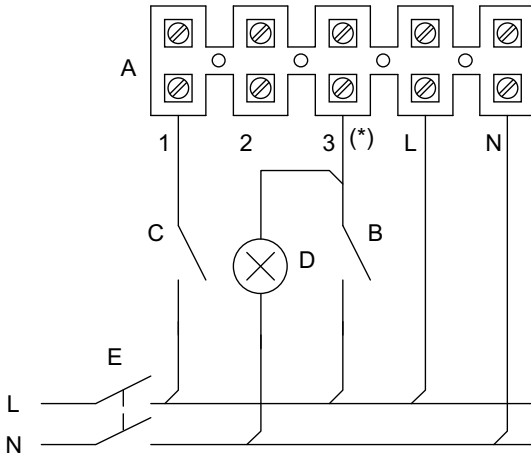

- A Hauptklemmleiste
- B 100m3/h Schalter
- C Ausschalter
- D Raumlicht
- E Bipolarer Hauptschalter

(*) Timed input

Accessori

Accessories

Accessoires

Zubehör

QE-MH



Kit per installazione ad incasso in strutture in cartongesso
Kit for recessed installation of plasterboard structures
Kit pour installation à encastrement pour structures en placoplâtre
Bausatz zum Einbau für Konstruktionen aus Gipskarton

QE - TEK



Kit per estrazione secondaria da WC
Kit for secondary extraction from toilets
Kit pour extraction secondaire de WC
Bausatz für sekundären Auszug aus WC

QE - UMB

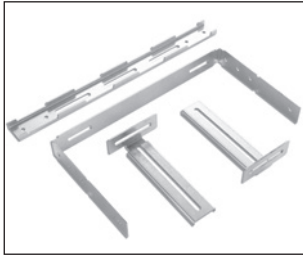

Staffa universale per installazione a incasso
Universal bracket for recessed installation
Étrier universel pour installation à encastrement
Standardwinkel für Einbauinstallation

QE - AD



Bocchetta per connessione a scarico da seconda stanza
Vent for second room connection
Bouche pour raccordement deuxième pièce
Stutzen zum Anschluss des zweiten Zimmers

QE - FBA



Adattatore per installazione scatole ad incasso
Adapter for recessed box installation
Adaptateur pour installation boîtiers à encastrement
Adapter für Installation der Wandeinbaukästen

QE - SPF



Cornice distanziale estetica muro
Aesthetic wall spacer frame
Cadre entretoise esthétique mural
Abstandsrahmen für ein besseres aussehen an der Wand

QE - CFR

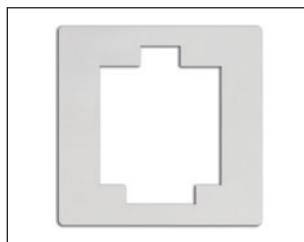

Cornice di tamponamento
Infill frame
Cadre de remplissage
Pufferrahmen

QE - SRK



填充框架

Kit per estrazione da secondo ambiente
Kit for extraction from a second room
Kit pour extraction de deuxième pièce
Bausatz für Auszug aus zweitem Zimmer

QE-MH

Kit per installazione ad incasso per strutture in cartongesso (fig. 1÷5)

Sono necessari:

1 supporto di montaggio (fig.2, A)

2 viti a testa esagonale (fig.1, A)

2 dadi esagonali (fig.2, B)

Il fissaggio alla struttura in cartongesso è realizzato per mezzo del kit apposito con supporti a parete (fig.4: A)

La staffa può essere accorciata in corrispondenza della tacca (fig.2, C).

QE-TEK

Kit per estrazione secondaria da WC (fig. 6÷8)

Per l'installazione in WC è necessario tenere presenti le normative dei paesi di installazione. E' sconsigliata l'installazione senza filtri, perché l'apparecchio e l'intero condotto si sporcherebbero.

Apertura pretagliata per attacco tubo di scarico (a destra o sinistra) (fig.6, A)

QE-UMB

Staffa universale per installazione ad incasso (fig. 9÷14)

Regolazione addizionale

Allineare la posizione di montaggio alla situazione corrente allentando le viti laterali nelle asole della staffa, in altezza e profondità. Stringere fermamente le viti.

Sono necessari:

staffa da muro (fig.12, A)

2 barre laterali (fig.11, A)

staffa di montaggio (fig.10, A)

2 viti a testa esagonale Mx16 (fig.9, A)

2 dadi esagonali M6 (fig.10, B)

4 viti autofilettanti M6x10 (fig.11, B; fig.12, B)

La staffa può essere accorciata in corrispondenza della tacca (fig.10, C).

Fissaggio a muro: fig.13. (A: allineare perpendicolarmente)

Misure modificabili; spazio tra il muro e il lato posteriore della scatola: fig. 14. (A: lungo, B: corto, C:corto ruotabile)

QE-AD

Bocchetta per connessione seconda stanza (fig.15÷16)

Apertura pretagliata per attacco tubo di scarico (a destra o sinistra): (fig.15, A).

Scarico verso l'alto. Connessione per scarico seconda stanza a destra o sinistra: (fig.15, B).

Bocchetta connessione per scarico seconda stanza QE-AD: (fig.15, C).

QE-FBA

Adattatore per installazione scatole ad incasso (fig.17÷20)

Adattatore per cartongesso, da utilizzare per inserire frontalmente scatole ad incasso in pareti di wc. L'accessorio è composto dall'adattatore e da 4 viti.

Fig.18: connettere il cavo ai terminali nella scatola; connettere e sigillare il tubo flessibile con la bocchetta di scarico. Non piegare il tubo.

Fig.20: installare perpendicolarmente. **IMPORTANTE:** la scatola non deve essere in nessun caso deformata.

Le viti non sono in dotazione.

QE-SPF

Cornice distanziale estetica muro (fig. 21÷24)

Fig.21: montaggio di QE SPF per coprire l'adattatore QE FBA.

Fig.22: montaggio di QE SPF per coprire i bordi irregolari dei fori nelle pareti.

Fig.23: montaggio di QE SPF per nascondere una sporgenza della scatola dal cartongesso (scarico posteriore)

Fig.24: montaggio finale: posizionare il pannello frontale di QE sulla cornice QE-SPF.

QE-CFR

Cornice di tamponamento (fig. 25÷26)

Consente di nascondere le imperfezioni dovute ad un'installazione non correttamente rifinita in un intonaco o su piastrelle o in aperture per l'incasso troppo ampie, che il QE non riuscirebbe a coprire completamente. La cornice è montata tra la parete e la parte anteriore del QE.

QE-SRK

Kit per estrazione da seconda stanza (fig. 27÷32)

Fig 27

0 scatola a muro

1 flangia a muro

2 filtro

3 telaio

4 pannello frontale

Fig 28

A.Profondità massima dell'incasso: 40 mm

B.Viti opzionali: se vengono utilizzate è necessario praticare i fori sulla parete posteriore pre-sfondata della flangia a muro.

QE-MH

Kit for recessed installation of plasterboard structures (fig. 1÷5)

Required:

1 mounting support (fig.2, A)

2 hex head screws (fig.1, A)

2 hexagonal nuts (fig.2, B)

Fixing to the plasterboard structure is carried out by means of a kit with wall supports (pos.A fig. 4).

The bracket can be shortened near the notch. (fig.2, C)

QE-TEK

Kit for secondary extraction from toilets (fig. 6÷8)

Keep in mind regulations of the countries of installation when installing toilets. Installation without filters is not recommended as the appliance and the entire duct would dirty.

Pre-cut opening for discharge pipe connection (right or left) (fig.6, A)

QE-UMB

Universal bracket for recessed installation (fig. 9÷14)

Additional adjustment

Align the installation position to the current situation, loosening the side screws in the bracket slots in height and depth. Firmly tighten the screws.

Required:

1 wall bracket (fig.12, A)

2 side bars (fig.11, A)

1 mounting bracket (fig.10, A)

2 Mx16 hex head screws (fig.9, A)

2 M6 hexagonal nuts (fig.10 B)

4 M6x10 self-tapping screws (fig.11, B; fig.12, B)

The bracket can be shortened near the notch (fig.10, C)

Wall mounting: fig.13. (A: Align perpendicularly)

Measurements can be modified: space between the wall and the rear side of the box: fig. 14 (A: long, B: short, C: short rotatable)

QE-AD

Vent for second room connection (fig.15÷16)

Pre-cut opening for discharge pipe connection (right or left): (fig.15, A).

Discharge upward. Connection for right or left second room discharge: (fig.15, B).

Connection vent for second room discharge QE-AD: (fig.15, C).

QE-FBA

Adapter for recessed box installation (fig.17÷20)

Adapter for plasterboard, to be used to insert recessed boxes on toilet walls at the front. This accessory is composed of an adapter and 4 screws.

Fig.18: connect the cable to the terminals on the box. Connect and seal the flexible hose with the discharge vents. Do not bend the hose.

Fig.20: install perpendicularly. IMPORTANT: the box should not in any case be deformed.

Screws not supplied.

QE-SPF

Aesthetic wall spacer frame(fig. 21÷24)

Fig.21: QE SPF assembly to cover adapter QE FBA.

Fig.22: QE SPF assembly to cover the irregular edges of holes in walls.

Fig.23: QE SPF assembly to hide a protrusion from the plasterboard box (rear discharge).

Fig.24: Final assembly: position the front QE panel on the QE-SPF frame.

QE-CFR

Infill frame (fig. 25÷26)

Hides imperfections due to an incorrectly finished installation on a plaster or on tiles or in openings or recesses that are too large that the QE would not be able to cover completely. The frame is mounted between the wall and the front part of the QE.

QE-SRK

Kit for extraction from a second room (fig. 27÷32)

Fig 27

0 wall recessed box

1 wall flange

2 filter

3 frame

4 front panel

Fig 28

A.Maximum depth of recess: 40 mm

B.Optional screws: if used, it is necessary to drill the holes on the rear pre-recessed wall of the wall flange

QE-MH

Kit pour installation à encastrement pour structures en placoplâtre (fig. 1÷5)

Accessoires nécessaires :

- 1 support de montage (fig.2, A)
- 2 vis à tête hexagonale (fig.1, A)
- 2 écrous à six pans (fig.2, B)

La fixation à la structure en placoplâtre est réalisée au moyen du kit conçu à cet effet avec les supports muraux (pos.A fig. 4).

L'étrier peut être raccourci au niveau de l'encoche. (fig.2, C)

QE-TEK

Kit pour extraction secondaire de WC (fig. 6÷8)

Pour l'installation dans les WC, il est nécessaire de se conformer aux normes en vigueur dans les pays d'installation. L'installation sans filtres est déconseillée étant donné que l'appareil et que le conduit dans sa totalité se saliraient.

Ouverture pré-découpée pour le raccord du tuyau d'évacuation (à droite ou à gauche (fig.6, A)

QE-UMB

Étrier universel pour installation à encastrement (fig. 9÷14)

Réglage supplémentaire.

Aligner la position de montage à la situation actuelle en desserrant les vis latérales dans les fentes de l'étrier, en hauteur et profondeur. Serrer fermement les vis.

Accessoires nécessaires:

- 1 étrier mural (fig.12, A)
- 2 barres latérale (fig.11, A)
- 1 étrier de montage (fig.10, A)
- 2 vis à tête hexagonale Mx16 (fig.9, A)
- 2 écrous à six pans M6 (fig.10, B)
- 4 vis M6x10 (fig.11, B; fig.12, B)

L'étrier peut être raccourci au niveau de l'encoche (fig.10, C)

Fixation au mur: fig.13. (A: aligner perpendiculairement)

Mesures modifiables: Espace entre le mur et le côté postérieur du boîtier: fig. 14 (A: long, B: court, C: court roulant)

QE-AD

Bouches pour raccordement deuxième pièce (fig.15÷16)

Ouverture pré-découpée pour le raccord du tuyau d'évacuation (à droite ou à gauche): (fig.15, A).

Évacuation vers le haut. Raccordement pour évacuation deuxième pièce à droite ou gauche: (fig.15, B)

Bouches raccordement pour évacuation deuxième pièce QE-AD: (fig.15, C).

QE-FBA

Adaptateur pour installation boîtiers à encastrement (fig.17÷20)

Adaptateur pour placoplâtre, à utiliser pour introduire de manière frontale les boîtiers à encastrement dans des murs de wc. L'accessoire est composé de l'adaptateur et de 4 vis.

Fig.18 Raccorder le câble aux bornes dans le boîtier. Raccorder et sceller le tuyau flexible avec la bouche d'évacuation. Ne pas plier le tuyau.

Fig.20 Installer perpendiculairement. IMPORTANT : le boîtier ne doit en aucun cas être déformé.

Les vis ne sont pas fournies.

QE-SPF

Cadre entretoise esthétique mural (fig. 21÷24)

Fig.21 montage de QE SPF pour couvrir l'adaptateur QE FBA

Fig.22 montage de QE SPF pour couvrir les bords irréguliers des trous dans les murs

Fig.23 montage de QE SPF pour cacher une saillie du boîtier du placoplâtre (évacuation postérieure)

Fig.24 montage final : placer le panneau frontal de QE sur le cadre QE-SPF

QE-CFR

Cadre de remplissage (fig. 25÷26)

Permet de cacher les imperfections provenant d'une installation à la finition imparfaite sur enduit ou sur carreaux ou en ouvertures trop grandes pour l'encastrement, que QE ne réussirait pas à couvrir complètement. Le cadre est monté entre le mur et la partie antérieure de QE.

QE-SRK

Kit pour extraction de deuxième pièce (fig. 27÷32)

Fig 27

0 boîtier mural

1 bride au mur

2 filtre

3 structure

4 panneau frontal

Fig 28

A.Profondeur maximale de l'encastrement: 40 mm

B.Vis en option : en cas d'utilisation, il est nécessaire de trouser la paroi postérieure préalablement enfoncée de la bride au mur.

QE-MH

Bausatz zum Einbau für Konstruktionen aus Gipskarton (Abb. 1÷5)

Benötigt werden:

- 1 Montagehalterung (Abb.2, A)
- 2 Sechskantschrauben (Abb.1, A)
- 2 Sechskantmuttern (Abb.2, B)

Die Befestigung an der Gipskartonkonstruktion wird über den entsprechenden Bausatz mit Wandhalterung hergestellt (Pos.A Abb.4)

Der Winkel kann in Höhe der Markierung gekürzt werden (Abb.2, C)

QE-TEK

Bausatz für sekundären Auszug aus WC (fig. 6÷8)

Für den WC-einbau müssen die gegebenen Richtlinie des Installationslandes eingehalten werden. Wir empfehlen den Einbau ohne Filter, da das Gerät und die gesamte Leitung sonst verschmutzt werden würde.

Vorgeschnittene Öffnung für den Anschluss der Auslassleitung (rechts oder links) (Abb.6, A)

QE-UMB

Standardwinkel für Einbauinstallation (Abb. 9÷14)

Zusätzliche Einstellung

Die Montageposition an die derzeitige Situation ausrichten, indem die seitlichen Schrauben in den Ösen des sowohl in der Höhe als auch Länge gelöst werden. Die Schrauben fest anziehen.

Benötigt werden:

- 1 Mauerwinkel (Abb.12, A)
- 2 Seitenstange (Abb.11, A)
- 1 Montagewinkel (Abb.10, A)
- 2 Sechskantschrauben Mx16 (Abb.9, A)
- 2 Sechskantmuttern M6 (Abb.10, B)
- 4 Schrauben M6x10 (Abb.11, B; Abb.12, B)

Der Winkel kann in Höhe der Markierung gekürzt werden (Abb.10, C)

Wandbefestigung: Abb.13 (A: Senkrecht ausrichten)

Veränderbare Maße. Raum zwischen Wand und hintere Seite des Kastens: Abb.14 (A:Lang, B:Kurz, C:Kurz drehbar)

QE-AD

Stutzen zum Anschluss des zweiten Zimmers (Abb.15÷16)

Vorgeschnittene Öffnung für den Anschluss der Auslassleitung (rechts oder links) (Abb.15, A)

Auslass nach oben. Anschluss für Auslass zweites Zimmer rechts oder links. (Abb.15, B)

Anschlussstutzen für Auslass zweites Zimmer, QE-AD: (Abb.15, C).

QE-FBA

Adapter für Installation der Wandeinbaukästen (Abb..17÷20)

Adapter für Gipskarton, Anwendung für das frontale Einsetzen der Wandeinbaukästen in WC-Wände. Das Zubehör besteht aus dem Adapter und aus 4 Schrauben.

Abb.18: Anschluss des Kabels an die Klemmen des Kastens. Anschluss und Versiegelung des Schlauchs mit dem Auslassstutzen. Den Schlauch nicht biegen.

Abb.20 Senkrecht montieren. WICHTIG: der Kasten darf keinesfalls verformt werden.

Die Schrauben werden nicht mitgeliefert.

QE-SPF

Abstandsrahmen für ein besseres Aussehen an der Wand (Abb. 21÷24)

Abb.21: Montage QE SPF zur Abdeckung des Adapters QE FBA

Abb.22: Montage QE SPF zur Abdeckung der unregelmäßigen Ränder der Wandbohrungen

Abb.23: Montage QE SPF zum Verbergen, wenn der Kasten aus dem Gipskarton hervorsteht (hinterer Auslass)

Abb.24: Endmontage: die Frontplatte von QE auf den Rahmen QE-SPF positionieren

QE-CFR

Pufferrahmen (Abb. 25÷26)

Mit ihm können die Mängel durch eine falsch durchgeführte Montage im Verputz oder auf Fliesen oder in einer für den Einbau zu großen Öffnung verborgen werden, wenn dies mit QE nicht vollständig möglich ist. Der Rahmen wird zwischen der Wand und dem vorderen Teil des QE montiert.

QE-SRK

Bausatz für Auszug aus zweitem Zimmer (Abb. 27÷32)

Abb. 27

0 Wandkasten

1 Wandflansch

2 Filter

3 Rahmen

4 Frontplatte

Abb. 28

A. Maximale Einbautiefe: 40 mm

B. Optionale Schrauben: wenn sie eingesetzt werden, müssen die Bohrlöcher an der hinteren Wand angebracht werden, die vorher für den Wandflansch durchbrochen ist.

QE-MH

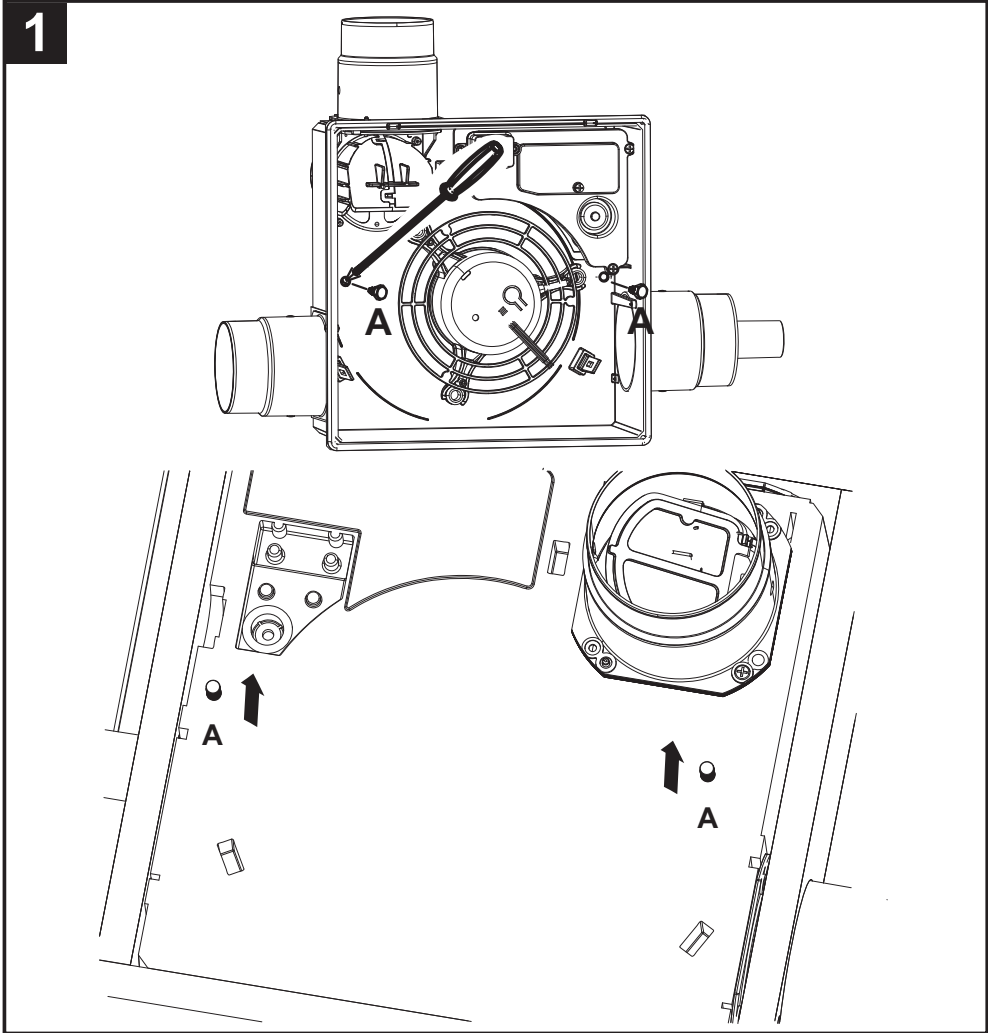

2

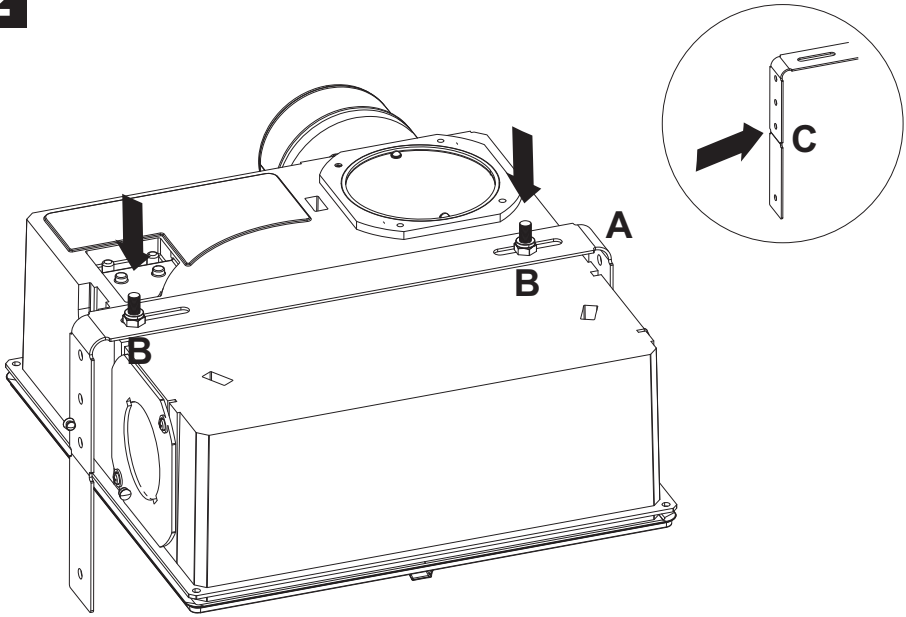

3

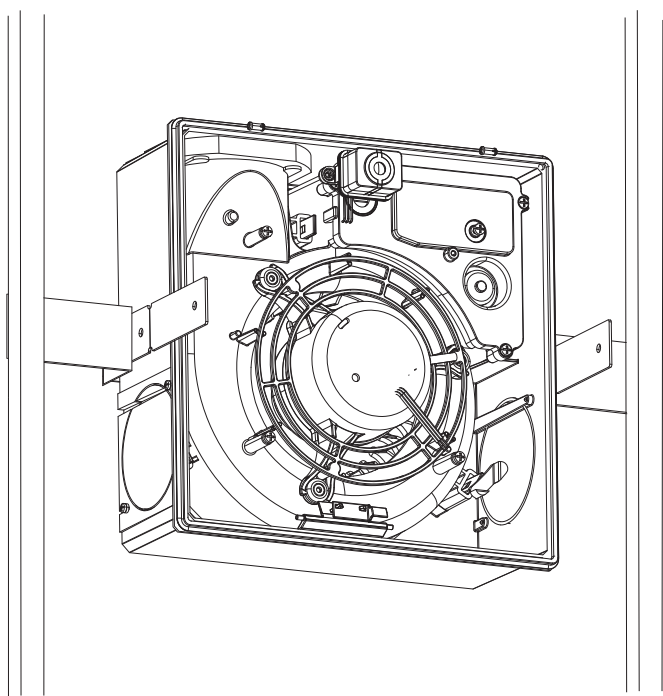

4

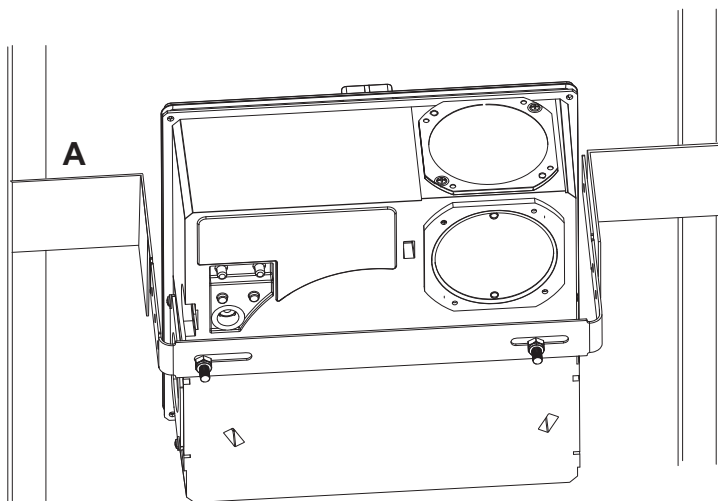

5

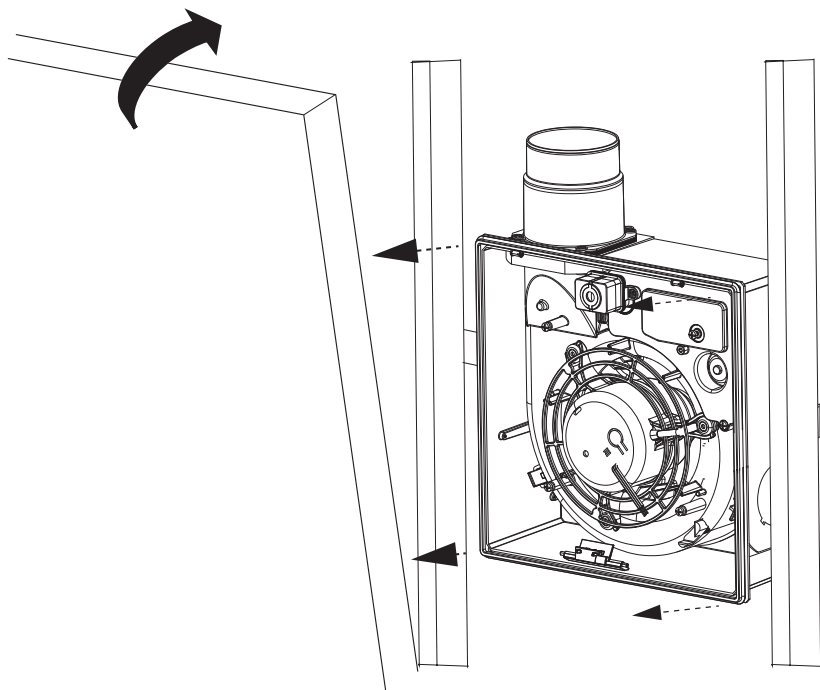

6

A

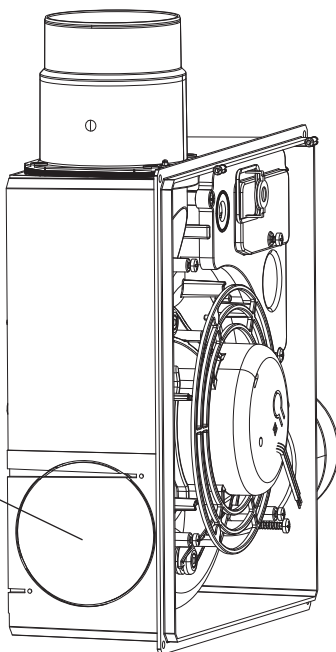

7

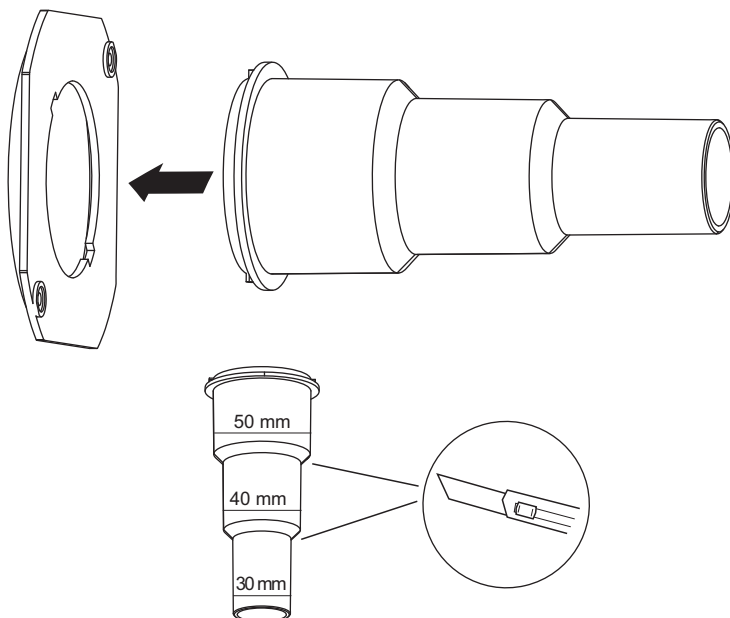

7-1

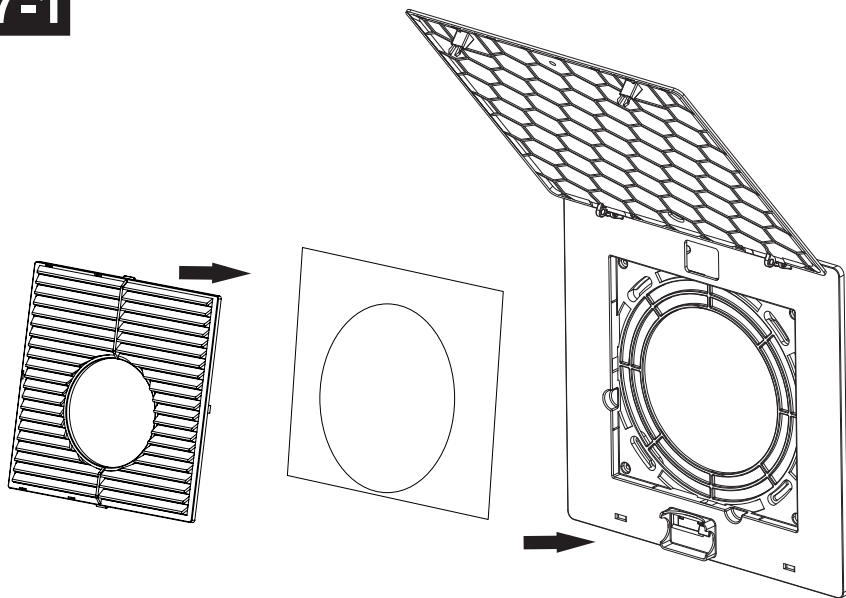

8

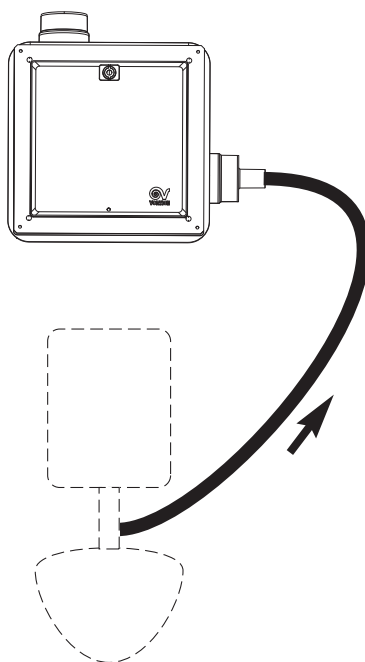

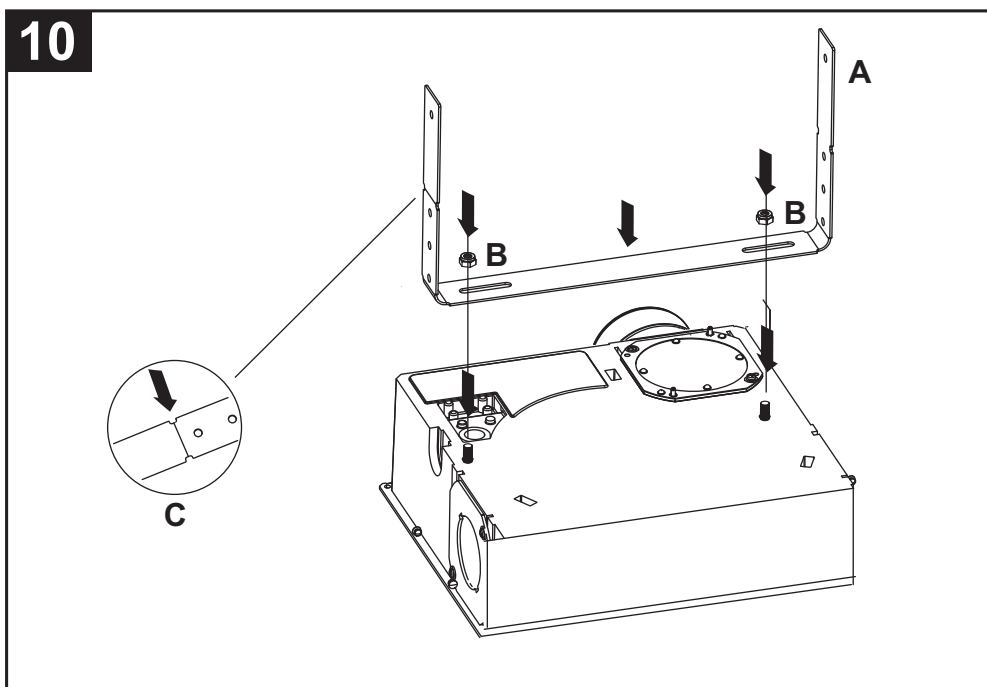
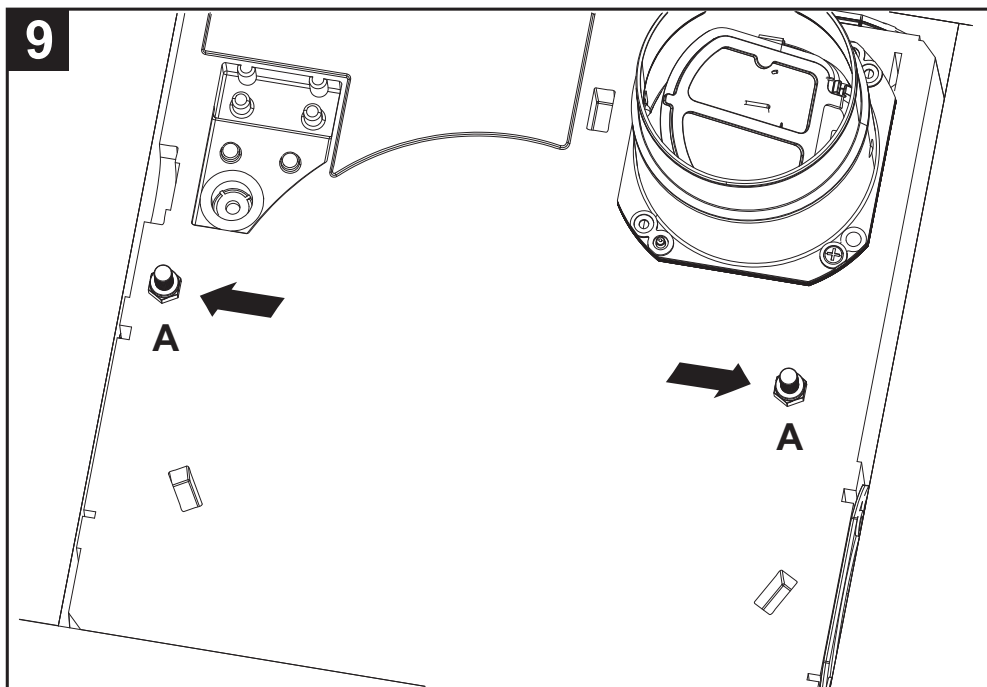

11

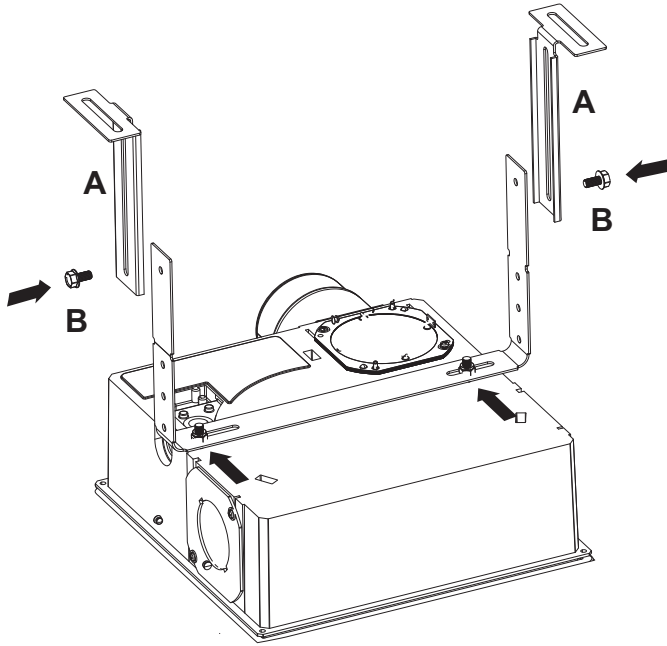

12

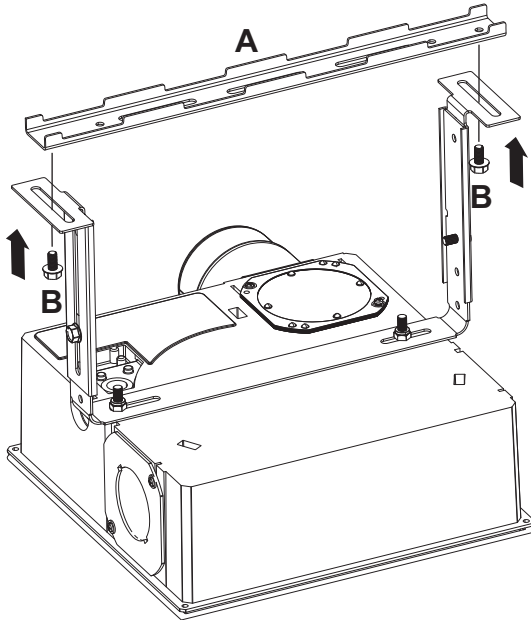

13

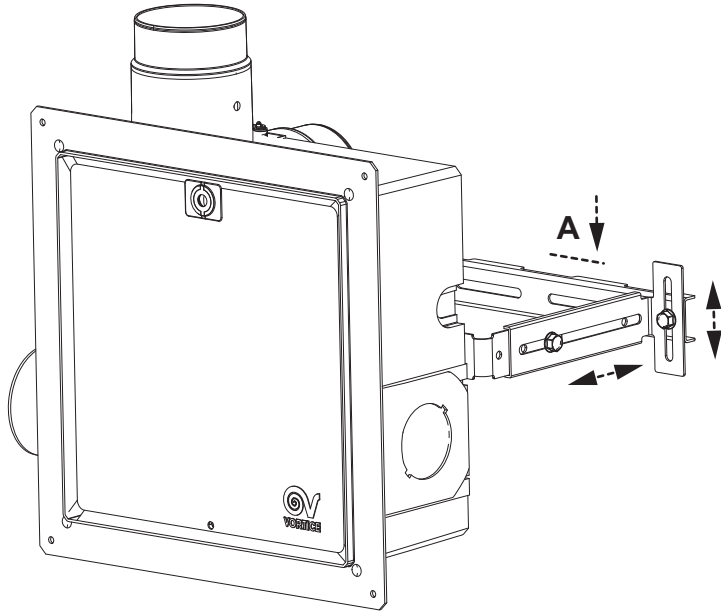

14



A
170 - 280 mm



B
95 - 205 mm



C
65 - 125 mm

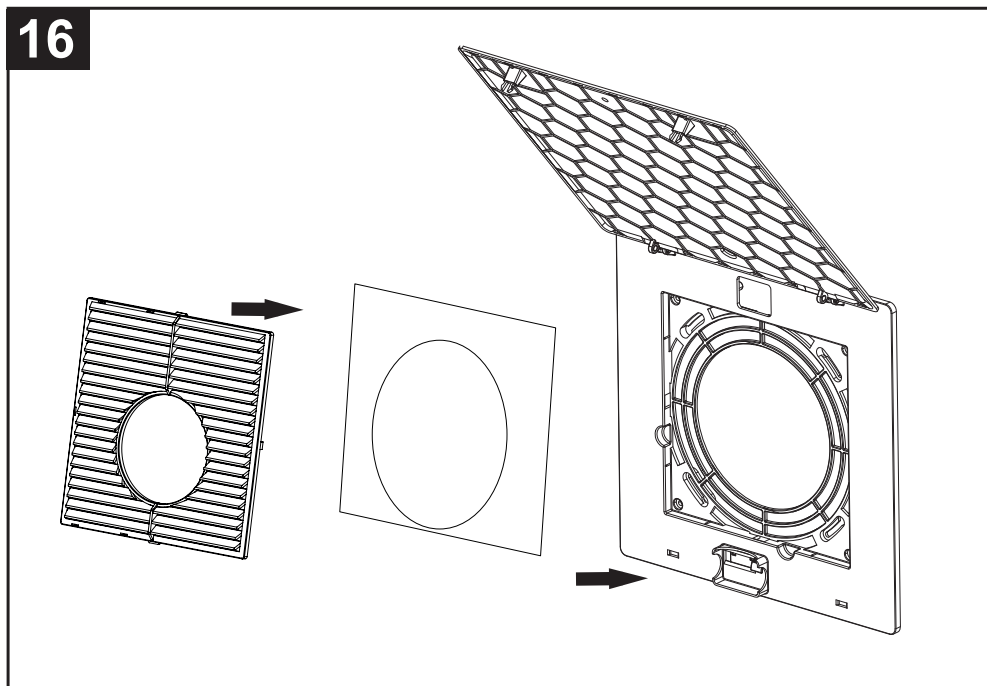
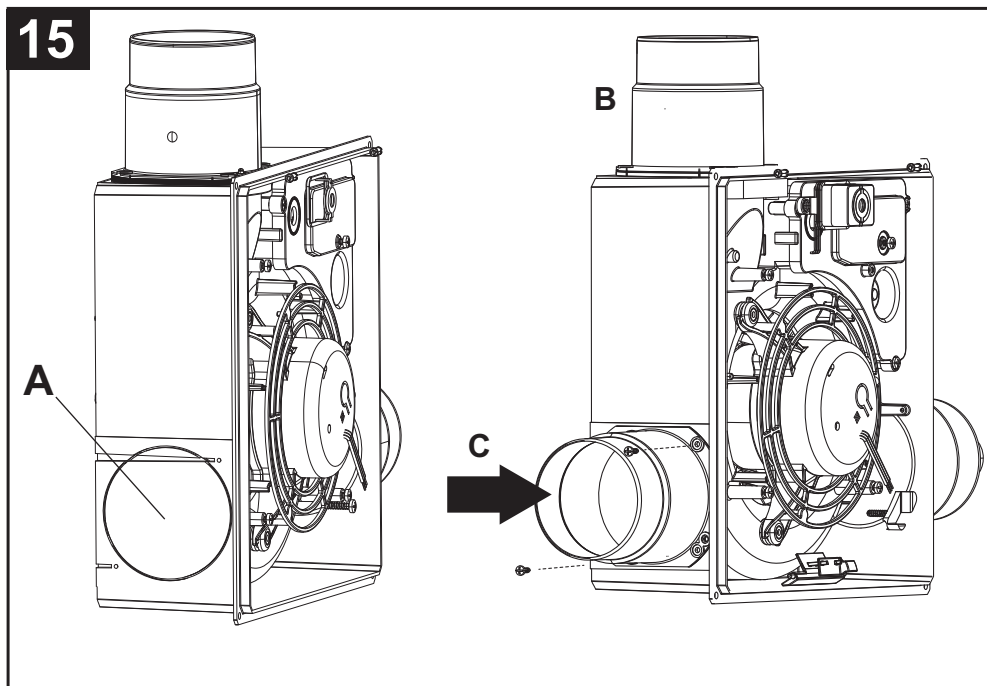

17

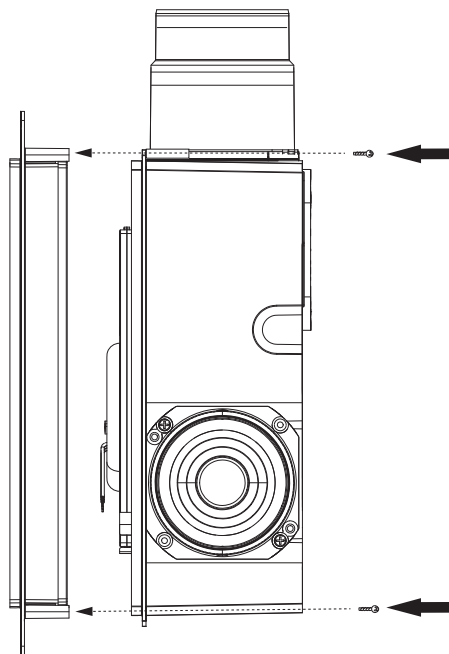

18

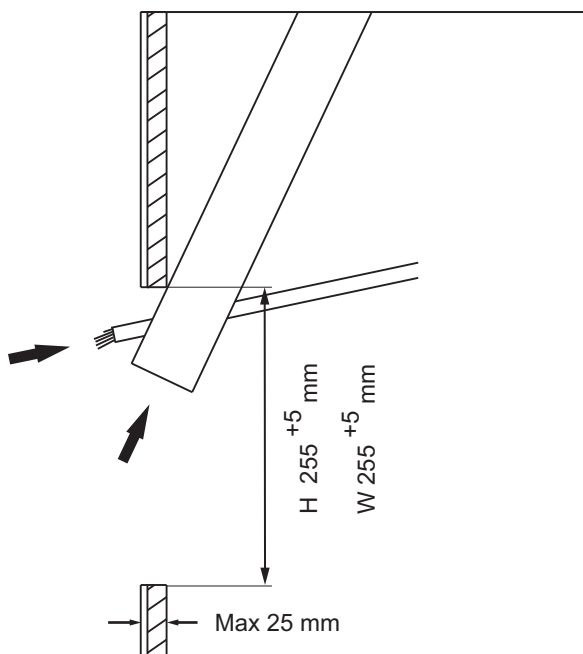

19

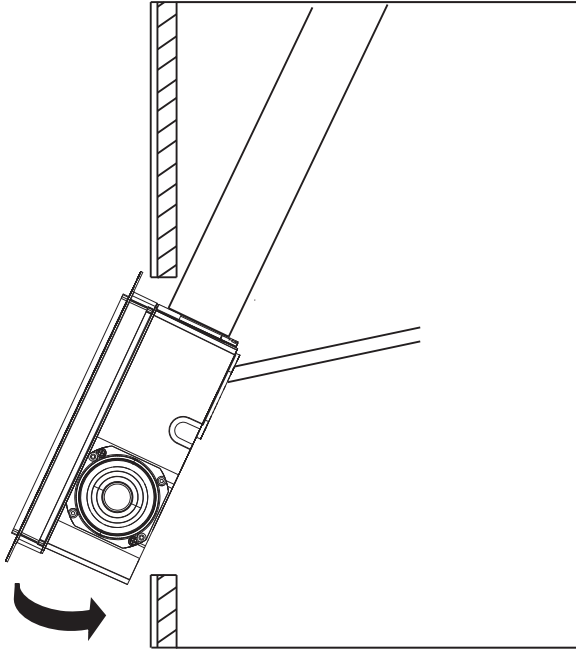

20

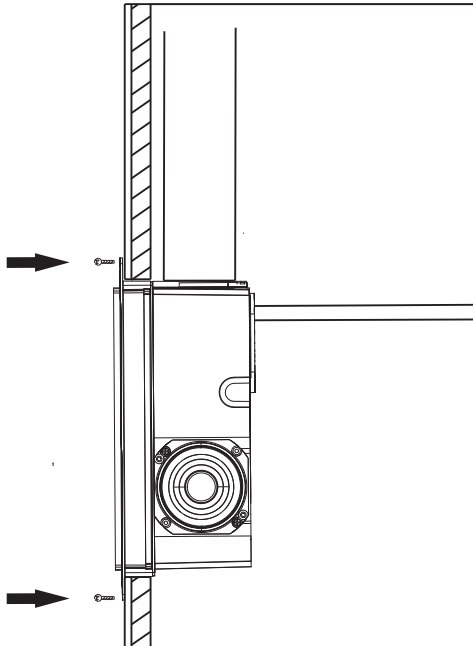

21

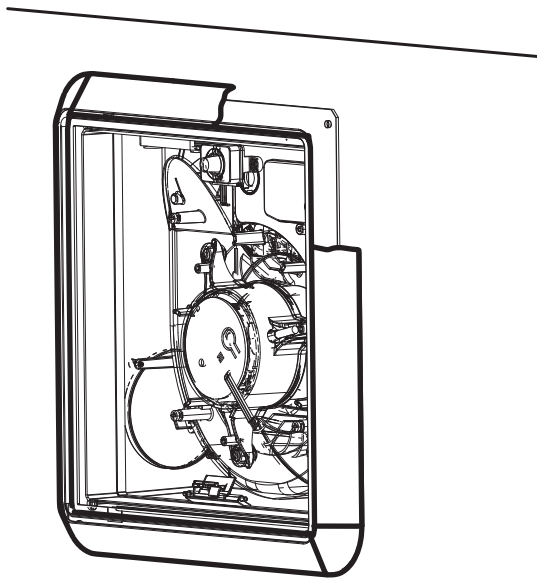

22

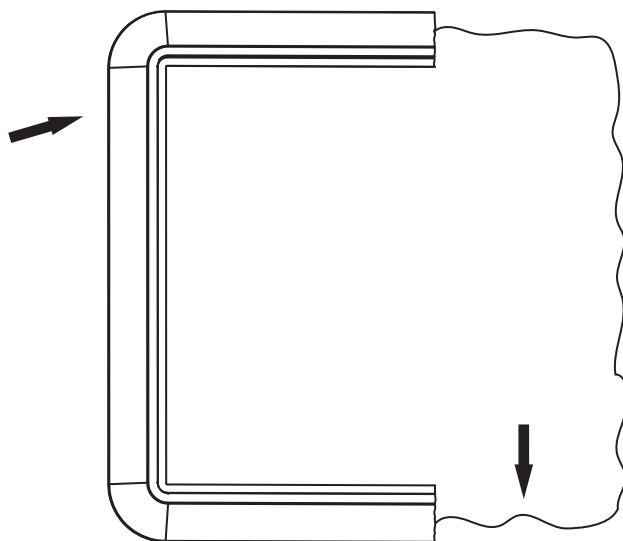

23

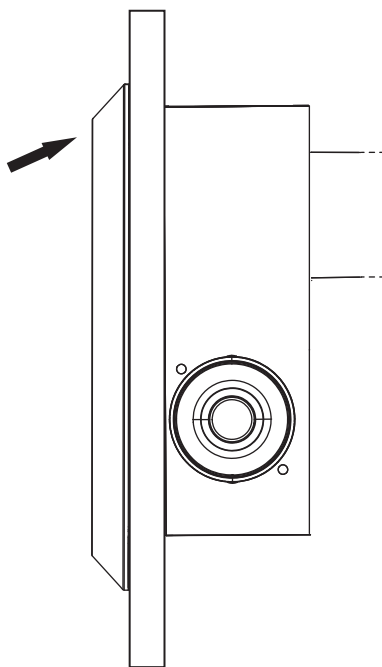

24

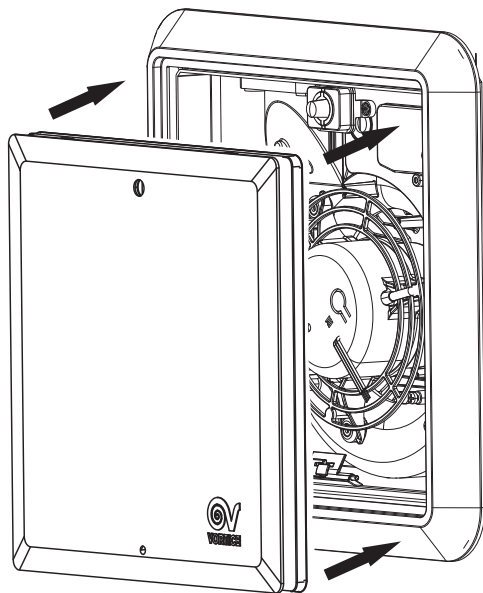

25

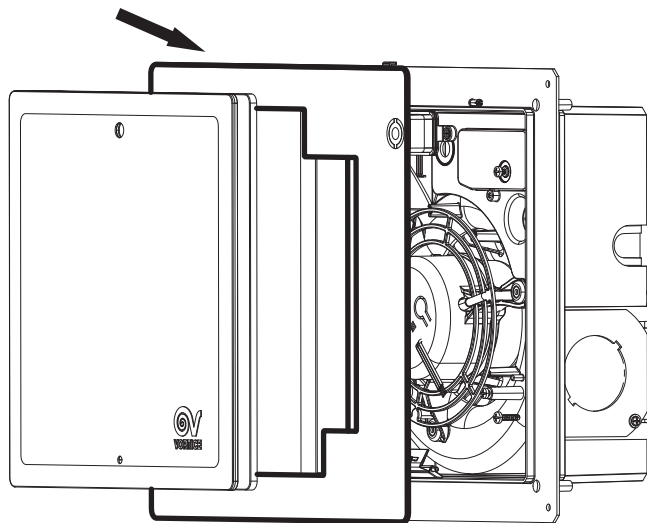

26

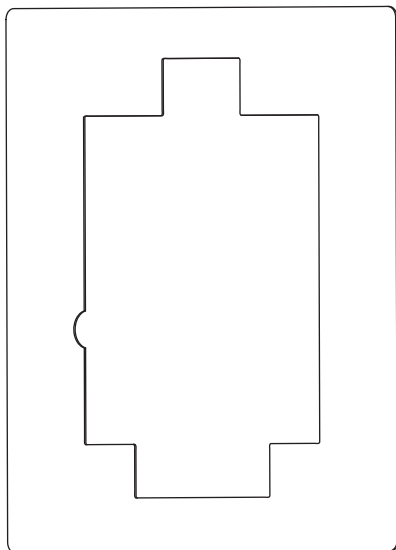

27

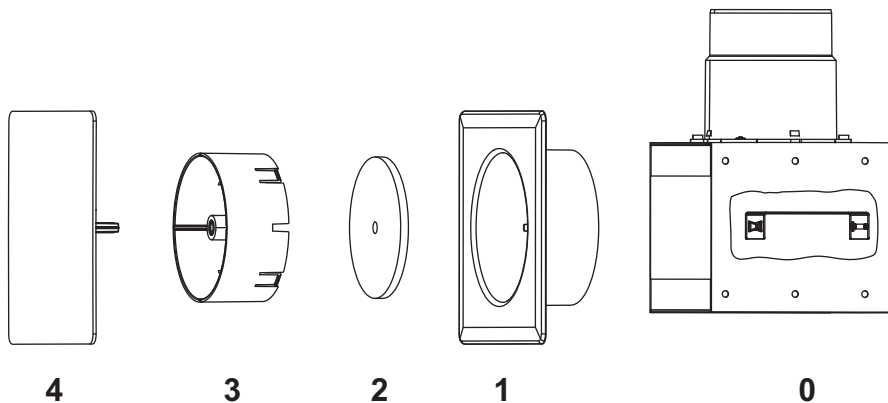

28

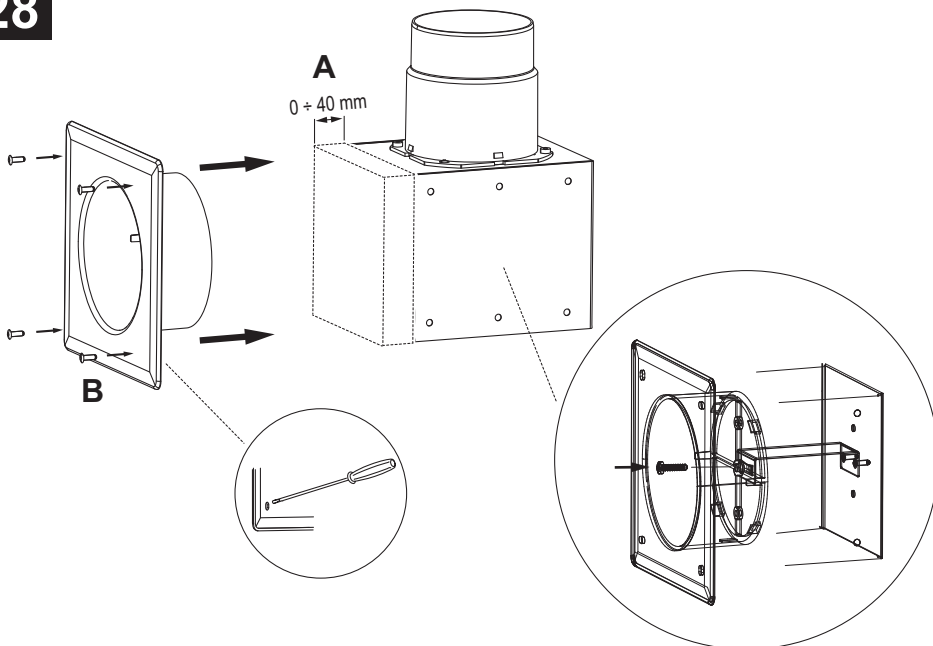

29

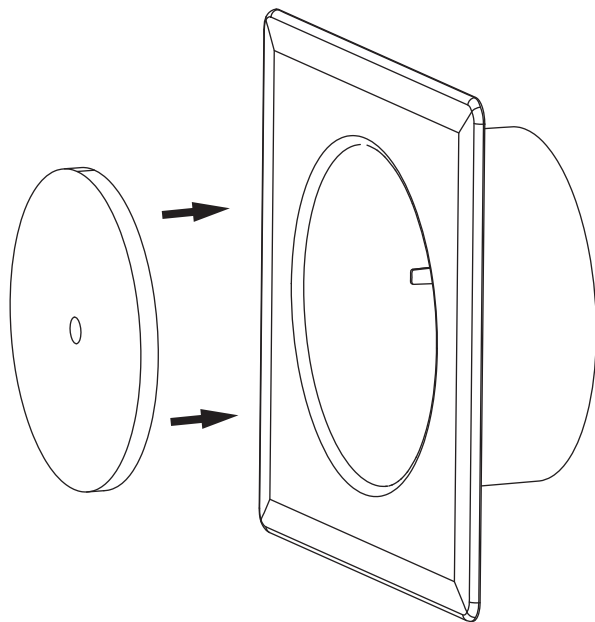

30

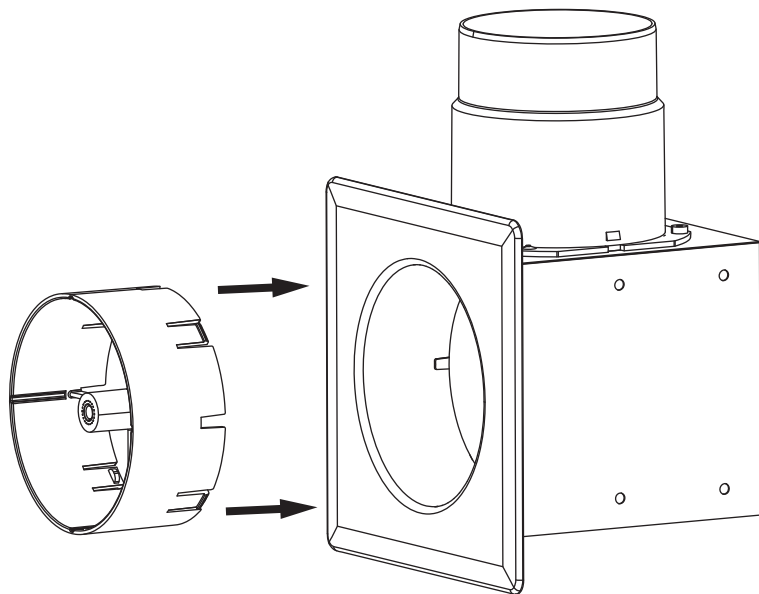

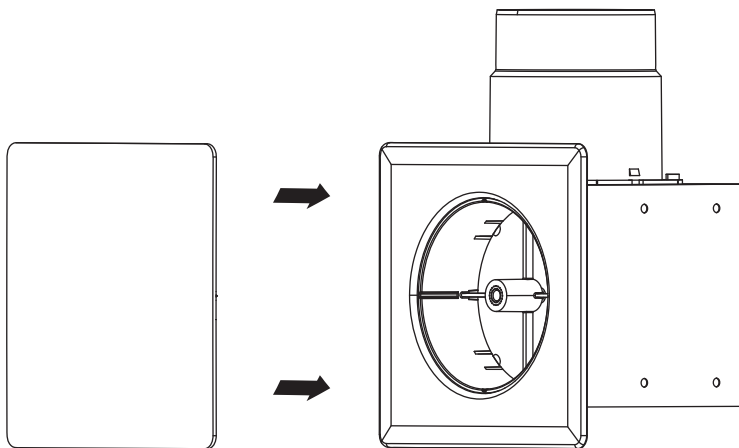
31**32**